

PROSPECTUS

CAL-C

(Centre for Advance Learning in Computers)

Gateway to a successful career

(Software, Hardware, Networking, Mobile Repair & Chip Level Courses)

For latest updates please visit our website www.punjabinfotech.in



visit our website
www.punjabinfotech.in

Printed and Published by
Punjab Infotech
(A State Government Undertaking)
18, Himalaya Marg
Udyog Bhawan, 5th-6th Floor
Sector 17, Chandigarh- 160 017
Ph.: +91 172 5256400-401
e-mail: contact@punjabinfotech.in

© Punjab Infotech 01-2025

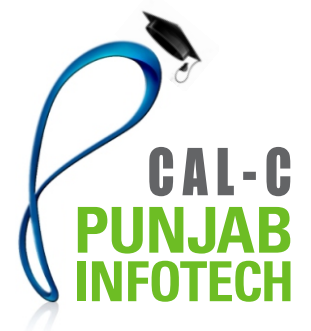

Prospectus

Software, Hardware, Networking
Mobile Repair & Chip Level Courses

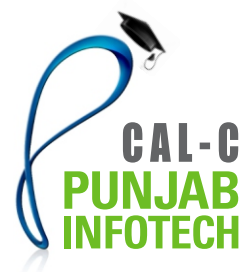

Message

IT/ITeS is widely acknowledged as a knowledge-intensive industry possessing tremendous potential for skill creation and employment and holds the key to development across the socio-economic spectrum.

Punjab Infotech, as the nodal agency for promoting IT/ITeS investments in the state, is taking multidirectional initiatives for promoting IT/ITeS sector in the state. It has a mission to create an enabling ecosystem for IT investors and one of the milestones of this mission is human capital development in the state.

To sustain Punjab's competitive advantage vis-à-vis the country's other IT destinations, we have redefined 'CAL-C' (Centre for Advance Learning in Computers) to function as an industry partner in creating an employable pool for the IT & ITeS industry in the state. Its basic role is to impart quality training to the youth of Punjab so that they are able to find employment/ self-employment in the field of IT/ITeS.

With its hand on the industry pulse, Punjab Infotech has identified needs of the IT and ITeS sectors and has been constantly upgrading its programs accordingly to translate student training into job opportunities. It also has an extensive network of 85+ hardware and software centres in the northern region where it has recorded praise-worthy success in spreading computer culture and literacy at grass root levels having trained about 1 Lacs+ Software & Hardware professionals up to 2023.

Punjab Infotech has facilitated Punjab Skill Training for Employment Potential (P-STEP) Program, an initiative of Department of Higher Education, aimed at increasing the employability of the students in the state with the IT/ITeS, BPO, KPO industry aimed at upgrading the soft skills and communication skills of the students.

Punjab Infotech has also provided Computer Training to 4000+ SC BPL candidates in last five years at CAL-C Centre under the Special Central Assistance Programme (SCAP), Welfare Department, Government of Punjab.

Our vision is to take Punjab into the next era of 'Knowledge Revolution' through the creation of a fertile ground for IT learning and development, following it up with the implementation of a strategically effective HR policy.

Managing Director
Punjab Information & Communication
Technology Corporation Limited
Chandigarh

Contents

1. About Punjab Infotech	1
2. Board of Directors	1
3. Demand of IT Professionals	1
4. Introduction to CAL-C	1
5. Objective	2
6. Infrastructure	2
7. Faculty	3
8. Library Facility	3
9. Training Methodology	3
10. Admission Policies	4
11. Career Counselling	5
12. Employability of Computer Course in India	5
13. JOBS @ IT	5
14. Courses	6
15. Lateral Entry	7
16 Examination System Pattern	8
17. Filling of Registration forms	8
18. Guidelines for Examination	8
19. Qualifying Marks	9
20. Re-Totaling / Re-Checking Procedure	9
21. Attendance	10

22. Examination - Results	10
23. Course Material	10
24. Syllabus	10
25. Certificates And Marksheets	10
26. Detailed Rules	11
27. Discipline	11
28. Right to Amend Rules	11
29. Jurisdiction	11
30. General	11
31. Software Programs	13
32. Fee Structure	15
33. Hardware Programs	27
34. Fee Structure	29
35 Examination System : Hardware Courses	29
36. Short Term Programs	34
37. Student Registration - cum - Admisssion Form	37
38. Rules & Regulations	41

About Punjab Infotech

Punjab Information & Communication Technology Corporation (Punjab Infotech) is a Punjab Government Undertaking under the administrative control of Department of Industries and Commerce, GoP, that has been successfully spearheaded the software training revolution through a strong network of CAL-C Centres' in Punjab since 1988. Punjab Infotech, is the premier agency of the Punjab state government in facilitating establishment of IT and IT enabled service's (ITeS) industry in Punjab, and training human resources for these industries. After the success in software skill set, CAL-C took a step further in the field of Advanced Hardware & Networking in 2003. CAL-C has an extensive network of franchise centres' in the region to provide quality computer training vis-à-vis industry requirement. At Present it has a network of about 85+ centers in Punjab, Himachal Pradesh.

Board of Directors

1. Mr. Gurinderjit Singh Jawandha,
Chairman
2. Mr. Pardeep Singh
Sr. Vice Chairman
3. Mr. Prabhbir Singh Brar
Vice Chairman
4. Additional Chief Secretary, Deptt. of Industries & Commerce, and Deptt. of Information Technology, Punjab
5. Principal Secretary Finance, Department of Finance, Punjab
6. Administrative Secretary, Department of Science, Technology & Environment, Punjab
7. Managing Director, Punjab Infotech
8. Additional Managing Director, Punjab Infotech
9. Director, Industries & Commerce, Punjab

Demand of IT Professionals

Information Technology has the potential to absorb 5.34 million people by 2023-2024. Where as in Punjab demand for IT Professionals will increase to 19 lac by 2023-24. Information technology will be a great economic booster as export revenue estimate of India will increase.

Above statistics clearly shows that future of IT and Knowledge industry is huge, there is a

great gap in demand and supply of IT professional in India.

Introduction to CAL-C

1. CAL-C is a Training Division of Punjab Information & Communication Technology Corporation Limited (A State Government Undertaking) established in 1988.
2. CAL-C had trained more than 1 Lacs+ students since its establishment.
3. CAL-C network spreads over with a network of 85+ centres in Punjab and Himachal Pradesh.
4. PGDCA offered by Punjab Infotech at CAL-C centre is recognised as equivalent of PGDCA of Punjab Technical University (PTU)
5. Certification of PGDCA Course of carried out by Punjab State Board of Technical Education (PSBTE)
6. CAL-C offers industry oriented curriculum with the modern educational techniques like computer based tutorials, use of LCD projectors in classrooms, internet access in the Centres and use of multimedia presentations in classrooms.
7. CAL-C offers both hardware and software courses, it also offers special programs for communication and soft skills which enables the students to practices the skills facilities during the course.
8. Courses offered are job oriented and of latest technology.
9. Classes are conducted for 2-3 hrs pattern, 600+ Hrs of study annually as per course requirements.
10. Study Material provided by CAL-C is of good Quality. Cost of study material is Included in the course fee.

Objective

1. Spread IT awareness among the youth of Punjab & India
2. Provide professional, continuous and upgraded training in IT as per the changing industry requirement and to improve job opportunities for the youth of Punjab
3. Maintain high quality training standards in the field of IT Training.

Infrastructure

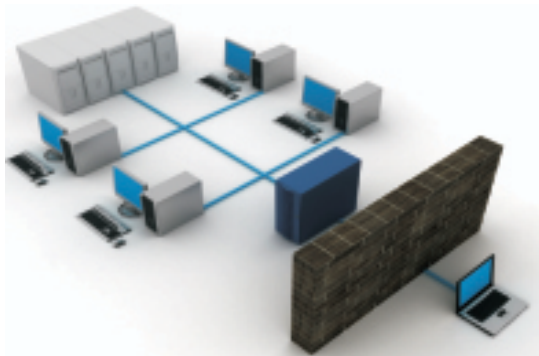

1. Well Equipped Labs & Classrooms:

The students can avail the laboratory facilities as per their need, which ensures their absolute familiarity with computers. All the CAL-C Centres are equipped with latest equipments to ensure that student gets the same environment in which they are expected to work after successfully completing the course. The classrooms of the CAL-C Centres are well equipped with modern facilities so that the students learn in a conducive, congenial and comfortable environment.

2. **Standardised Structuring:** Each CAL-C Centre Comprises a set pattern of classrooms and computer laboratories, This is to maintain the student-instructor ratio at an optimum level and to ensure individual attention and interaction, Each centre has a standardised infrastructure and equipment so that all the centres are at par with each other.

3. **Computer Laboratories:** State-of-the-art test equipment is necessary in each laboratory for providing a good practical grounding to students. It is our endeavour that students are well exposed to the latest equipment so they become well versed with the practical handling of the same. Our aim is to rein force the-oretical with sou nd practical grounding.

4. **Teaching / Training Aids:** Training, innovation and creative training techniques contribute a lot to effective communication with the students. Equipment ranges from analog and digital trainers, Cathode Ray Oscilloscope (C.R.O), PC trainer etc, as teaching aids. LCD projectors, Automated slide shows of courses on the normal black board are used to improve class room communication. This enables the faculty members to conduct live demonstrations in the class, there by not only increasing effective ness of the instruction but also inculcating a habit of selflearning among students.

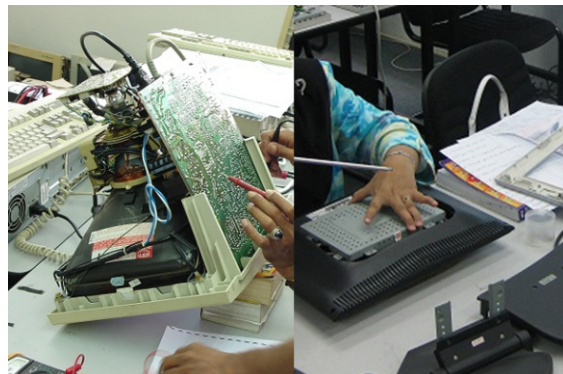
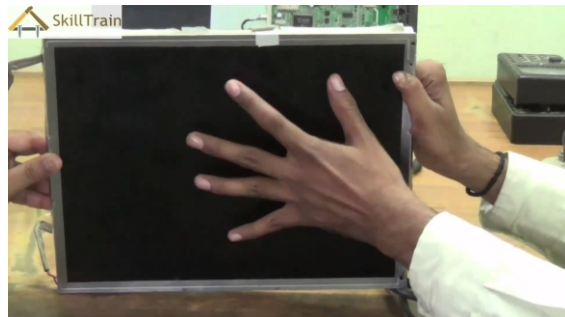

Faculty

The faculty at CAL-C Centres consists of qualified and experienced trainers and staff. The faculty has desired experience / specialisation in the particular area of technology being covered. At CAL-C, guest speakers from other organisation/institutions are also invited for lectures and discussions



Library Facility



CAL-C Centres have well stocked library. The library facility is available in all the CAL-C Centres with good number of books of all the leading publications.

Any students can become a member of library by paying a refundable amount of Rs. 500/-. He/She can avail this facility by using library reference books, latest magazines and other material.

Training Methodology

The training methodology followed by CAL-C is practical oriented; depending on the requirements of the course participants are provided a combination of theoretical and practical input. The following methodologies are used:

- Classroom instructions
- Exercises and practicals
- Class room study
- Home submissions
- Group consultancy with professional experts
- Film and audio visual presentations
- Group and panel discussions
- Computer demonstrations through multimedia kit
- Practical Training on computer after every theory class

1. **Written Material:** Comprehensive printed study material especially designed for self-study for both theory and practicals is supplied in batches to the CAL-C Centre for every long term course and to every student. Students have to collect the material pertaining to his/her course free of cost.

- (a) Student's who have passed the required qualification but their final DMC or worksheet is awaited from the Board/University will be considered as "Provisional".
 - (b) Compartment / Result awaited / Result dispute cases, where pass result is not declared cannot apply for short / long term courses.
 - (c) Student has to submit the copy of required DMC or worksheet on or before the last date of submission of exam form (2nd Semester is case of two semesters & 1st Semester in case of 6 months Course), after that the student will be treated as dropped (for long term course) For short term courses submission of documents is 15 days before the competition of the course, after that the student will be treated as "Dropped".
2. **Seminars and Workshops:** Issues of current interest in the field of Technologies of Computer Hardware Telecommunication and Networking are the theme of the seminars and the workshops organized by the respective CAL-C Centre. These seminars are basically for the students who are registered for Diploma courses However, other students from the centre can also attend the seminars. It helps them transcend the narrow confines of a laid down syllabus. Speakers familiar with the industry are invited to address these sessions.
- Intelligent, ethical, articulate and active individuals with a will to upgrade their skills are encouraged to pursue the CAL-C course programs.

Admission Policies



1. The applicant has to submit a complete application along with relevant enclosures / documents to the CAL-C Centres well within the due date. The centres will forward the same to the CAL-C HO. If the application is complete in all respects and the CAL-C HO is satisfied with the applicant's eligibility for admission into the respective program, the student will be granted admission to that program. The right to accept or reject any application is reserved with the CAL-C HO.
2. (a) Students who have passed the required qualification but their final DMC or Marksheet is awaited from the Board /University will be considered as "Provisional".
- (b) Compartment/Result awaited /Result Dispute Cases, where pass result is not declared can not apply for short/long terms courses.
- (c) Students have to submit the copy of original DMC or Marksheet on or before the last date of submission of Exam Form (2nd semester in case of two semesters & 1st semester in case of 6 months courses), after that the student will be treated as dropped (for long term course). For short term courses, submission of document is 15 days before the completion of the courses, after that the student will be treated as "Dropped".
- (d) Registration of student under STC (Short Term Courses) is open through out the year.
- (e) STC (Short Term Courses) certificate will be issued to students with confirmed admission status only.
- (f) LTC Student enrolled after the due date will be considered eligible for next session.
3. An identity card will be provided to students after their enrollment in a course program by the centre Head.
4. Students must also ensure that CH has submitted their Admission form for long Term/Short term courses with CAL-C H.O. as per the schedule dates. (visit www.punjabinfotech.in for details)
5. Students must ensure that they have received the registration number issued by PICTC with in a month of the date of registration particular course.

Carrer Counselling



Regular interaction with experienced academicians, industry experts keep the students abreast with the ever-changing trends of the market. The staff at the CAL-C Centre always extends a helping hand to students to guide them in all their queries related to their careers.

Employability of Computer Course in India

Market Overview

Unlike the traditional industries, the IT sector is people intensive and creates vast employment opportunities. Over the last few decades there has been tremendous growth in IT, which has almost revolutionized the very outlook of the world. The economy of any country is no longer measured by strength of traditional industries, but by its technological advancement. It is estimated that knowledge based business would contribute two third of the growth in global GDP in the next ten years.

In a developing country like India, IT makes it possible to leapfrog many of the physical barriers and deliver basic needs like education to people in areas that either do not have facilities or are inaccessible. With the decreasing cost of instruments and services like personal computers, cell phones and internet, direct benefit of IT sooner than later would be reaped even by the illiterate and disadvantaged.

Jobs@IT

India is looked upon as intellectual IT hub across the globe and we are training our students in the field with latest job oriented syllabi. Our students are being trained to cater to the need of BPO; IT enabled services, CAD-CAM, programming, system designs and support system. Our courses in IT lead to the career opportunities such as IT Consultant Hardware Design Engineers, System Designers Programmers, System Analyst, Software Engineering, Training Faculty, R & D Scientist EDP Manager, Programmer, System Specialist/Manager and Project Manager etc.

Hardware Jobs

Hardware refers to computer chips, circuit boards, computer systems and related equipment like keyed equipment such as keyboards, modems and printers. Hardware jobs are in manufacturing of computers and ancillaries, assembly, marketing and maintenance.

Software Jobs

System Programmer/Software Engineer: Systems Programmers Research, develop and adapt application programs for computer systems. Systems programmers and software engineers find employment with software firms and computer manufactures etc.

Enterprise Resource Planning (ERP)

ERP software is used planning for the resources of the entire worldwide network of an enterprise. Sales, services, distribution marketing, purchase, manufacturing, inventory, finance, accounts etc. are integrated on one software backbone. ERP is a system solution for enterprise wide computing which combines resource planning and integration of all business functions manufacturing, distribution and finance applications to synergies the resources of an enterprise.

Web Options

Professionals in dotcoms design web pages or take up a technical job on the server side. Website of education, business, services, institution, organizations, agencies provide ready options for work. Growth of the internet and the expansion of the World Wide Web have generated a variety of occupations relating to the design, development and maintenance of Web sites and their servers

Networking

Networking experts give connectivity to the various system nodes over a local or wide area network (LAN/WAN). Designing, building and maintaining information networks, within or between organizations, is their task. Networking is the fastest growing segment in the communications field, with a growth of around 35% annually. The job entails analyzing, installing and configuring the company's network. Monitoring network performance, troubleshooting and maintenance are major responsibilities. Emerging Technology in Network is internet security.

Multimedia

Multimedia involves, computing and audio visual technologies to fuse video, text, graphics web designing, animations etc. in meaningful way. Animators, Sound technicians, graphic artists, video technicians are multimedia professionals

Call Centres

A call centre is a place that has adequate telecom facilities, trained consultants, access to wide database, internet and other on-line support infrastructure in order to provide information and support to customers on real timebasis.

Operating Jobs

People, who enter data into the machine, exist in all user and consultancy units, large and small. In a large or medium firm where computer operators are involved in work on a large scale, there is usually the EDP Manager for the information system. Computer operations involve data entry, desk top publishing, etc. Employment is in organisation with a large database, in publishing and dotcoms. Computer courses after 10+2 are required for these jobs. They often handle peripheral electronic devices

Marketing Jobs

Computer marketing people at the regional office are supported by other people who tell them what they should be selling to whom and what strength their products have over their competitors. Market researchers study their products and the competitors. Market Research, Market Analysis requires computer professionals with a marketing background. Options for jobs exist with manufacturing and software designing firms.

Entrepreneurs

The computer industry provides services to departments of the same company or to individual clients. These services could range renting PCs to publishing on a computers helping customers select computers for developing software and training computer professionals. Many software professionals with experience have switched over to lucrative consultancy practices. The demand for specialists is also increasing. Even desk top publishing is catching on fast.

Courses

Eligibility

Courses at CAL-C are tailored for students with different academic qualification. Admissions to different courses will be strictly as per the eligibility criteria applicable for that course.

Payment of Fees

The course fee for the various courses will be paid in advance. For courses of duration one year & above fee can be paid in semester wise. The fee instalments are to be paid latest by the seventh day of the month to CAL- C Centre. CAL- C Centre is liable to charge fine or cancel the candidature of the student in case of delay. Fee once paid shall not be refunded and is non transferable.

10% Concession in fee is admissible in case of candidates belonging to SC/ST categories & Physically handicapped persons subject to procedures laid down by the PICTCL & furnishing of evidence of relevant documents This concession also extends to Govt. Employees (State/Central).

Advantages @ CAL-C

- Job Oriented & Latest Technology courses
- Classes conducted on 2-3 Hrs Daily Pattern 600+ Hrs of study annually
- All courses conform to Punjab Infotech nomenclature and regulations
- Course material of good quality provided by Punjab Infotech
- Regular updates on software & hardware innovation term with Punjab Infotech & associate with IT industry
- All round development of students through various co-curricular activities
- Affordable fee structure
- Courses can be pursued along with regular studies also

Lateral Entry

Various long & short term courses are designed for multiple entry and exit. The candidates can enroll for the courses based on basic qualification and lateral entry qualification.

Basic qualification : For Certificate, basic qualification is 10th. For Diploma, basic qualification is 10+2. For Post Graduate Diploma, basic qualification is graduation. The specific provisions are indicated under respective course headings.

Lateral entry qualification : Lateral entry is an opportunity given to a candidate having the basic qualification and previous qualification in the relevant field to enter a higher semester. from one course to other CAL-C Course

However such students will be required to appear and qualify in the previous semester/ relevant papers.

The various entry and exit points for respective courses are illustrated below graphically.

The details of eligibility criteria and fee structures are indicated in respective course headings. **Lateral entry fee is Rs.500/-** in addition to the course fee.

Please note that Registration form is to be filled by the candidate only, so that centre may forward to CAL-C, H.O.

Examination System Pattern :

1. Examination will be held for long term courses (6m & above) and short term courses C01/C01F/ C14, C15, C16, C18 & C21/C21F only.
2. Examination will be held in Feb & August for long term course except PGDCA (Details can be viewed from website)
3. Examination for PGDCA courses will be held in Mar/ Sept. & will be conducted by Punjab State Board of Technical Education & Certificate will be used by PSBTE for the qualified Student.
4. Examination details can be viewed from our website : www.punjabinfotech.in
5. Examination for long term courses will be conducted as follows: Theory (INT:20; EXT: 80 Marks), for complete details logon to www.punjabinfotech.in
6. Participation certification will be given to the students enrolled under short term courses only other than C01/C01F /C14/C15/C16,C18 & C21/C21F Course. Exams of C01/C01F/C14/C15 will be conducted monthly dates for C16 & C18 exam will be intimated to centres.
7. If student fails to appear for C01/C01F/C14 /C15/C16/C18/C21/C21F exams in the schedule date Re-exam fee to be paid by student to PICTC.

Filling of Registration forms

1. The student must be extremely careful while filling the registration and examination forms. He must ensure that the spelling of his name & father's name etc. are correct and these parameters are matching with those given in his/her certificate of board examination (10th class)

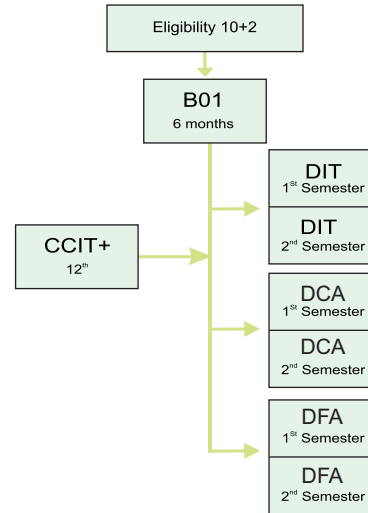

2. The ATCs are supposed to prepare the database of their students on the basis of the forms. It is this database which is used for the preparation of registration cards, admit cards, marks sheets & certificates, If a student makes any mistake while filling the forms or the ATC supplies erroneous data and wants the corrections to be implemented at a later stage then the same will be done on receiving an application through the ATC along with the following charges :-

- | | |
|--|-----------|
| (a) Corrections in Registration card/Admit Card: | Rs. 50/- |
| (b) Correction in Mark-Sheet | Rs. 200/- |
| (c) Correction in Certificate: | Rs. 200/- |

Registration Number of students will be issued by PICTC to respective CAL-C Centre (Any correction required may be informed within 7 days to PICTC).

For PGDCA Course, Guidelines of PSBTE to be followed

Guidelines for Examination

1. Examinations for LTC will be conducted twice in a year in the months of February and August. Date and details of examination will be communicated to franchisee. Same can be viewed on website

2. Examination Schedule will be communicated to franchise centers through e-mail & will be uploaded on the website of CAL-C for reference of franchise centers or students.
3. Formats / Information related to examination i.e. IA / Practical / Project marks criteria etc. can be downloaded from website itself.
4. i) CAL-C Head Office will conduct theory and practical examinations at respective centers. If the number of students appearing in the examinations is less than 20, then franchise centre will not be made examination centre and students of the centre will appear in nearby examination centre, For PGDCA course number of enrolment is min. 30, else examination will be conducted at nearest centre

ii) For C01/C01F, C14, C15, C16, C18 & C21/C21F Course criteria for exam can be viewed on website.
5. The detailed syllabus can be viewed from website.
6. Examination pattern, can be downloaded from website & is also mentioned in the prospectus.
7. The examination formats / details can be viewed from website.
8. 75% attendance of student is required for a student to appear in examination.
9. Number of theory and practical papers and their duration etc. in each course will be intimated through student prospectus and on website.
10. For PGDCA, Guidelines of PSBTE will be applicable. (Visit the website of Punjab State Board of Technical Education)
11. Examination will be conducted by the empanelled Examination Supervisor (ES) of Punjab Infotech. ES are empanelled as per the criteria laid down by Punjab Infotech.

12. Centre Heads are required to give undertaking for proper conduct of exams at centre as provided by the Punjab Infotech. Centre Head will be overall responsible for conduct of exam smoothly at his/her centre.
 - (a) Students who have passed the required qualification but their final DMC or Marksheet is awaited from the Board /University will be considered as "Provisional".
 - (b) Compartment/Result awaited /Result Dispute Cases, where pass result is not declared cannot apply for short/long term courses.
 - (c) Students have to submit the copy of original DMC or Marksheet on or before the last date of submission of Exam Form (2nd semester in case of two semesters & 1st semester in case of 6 months courses), after that the student will be treated as dropped (for long term course). For short term courses, submission of document in 15 days before the completion of the courses, after that the student will be treated as "Dropped".
- ii) Registration of student under STC (Short Term Courses) is open through out the year.

Qualifying Marks

Minimum pass marks in each paper will be 40% (external marks).

Grading : Grading is done as per following table

Percentage Grading Marks Obtained	Grade
80% & above	'O'
70% - Less than 80%	'A'
60% - Less than 70%	'B'
50% - Less than 60%	'C'
40% - Less than 50%	'D'
Less than 40% /Fail in any subject	'Attended'

Re-totalling / Re-checking

Procedure

Student can apply for Re-totalling/ Rechecking within 10 days from the date of declaration of result by PICTC by paying Rs 100/- per paper for Re-Totalling and Rs. 200 for Re-checking. The franchisee must send the request for Re-Totalling/Rechecking in the format given.

Attendance

Students are to be present in all scheduled class periods (including extra classes). Students must be regular and punctual in attendance of classes, tutorials and submission of term work on various subjects. All matters related to student absenteeism are to be communicated to parparents in writing Since CAL-C belives that attendance in class is compulsory part of the learning experience.

Examination - Results

The term-end examination schedule and list of the examination centre will be informed through e-mail to CAL-C Centres & also can be checked/ viewed through website www.punjabinfotech.in The examination centre can be different from the CAL-C Centre and Eligible students will be given admit cards to appear in the examinatin. Students will have to produce the identity card and admit card appear in the end-term examinatin at the examination centre. The examination pattern will be provided to the students by CAL-C Centre and the same can be viewed from website

The results will be published on the web site www.punjabinfotech.in and the marks card will be sent to the respective CAL-C Centre. Result will be emailed to the respective centre. If a student fails to clear any of the papers, she/he has to re-appear for the relevant Subject paper by applying to the CAL-C HO through the re exam form along with relevant fees, within the due date specified by the CAL-C HO

Two extra chances upto 1 year duration course, will be given to the student, provided Royalty for 2nd sem. must have been paid to PICTC

Course Material

1. All course material will be provided to the students by the Authorised Training Centre free of cost. Notes will be provided where books are not available.
2. The course material once issued to the student will not be exchanged for any reason whatsoever even if a revised edition has been brought out by CAL-C HO.

Syllabus

1. All CAL-C Courses will be conducted in accordance with the syllabus as prescribed by PICTC.
2. The CAL-C HO reserves its right to modify add, delete or alter the syllabus of any course at any time so as to incorporate the State-of-the-art Technology.

Certificates and Marks Sheets

On successful completion of the course module and passing of the examination in all the papers specified for that course module, a certificate along with the Marks Sheet will be awarded by the CAL-C HO.

In case all the papers of courses are not passed only attended Certificate will be issued, in case of short term course Certificate or Participation Certificate will be issued.

Duplicate/ Re issue certificate will be issued at a fee of Rs. 200/-

For PGDCA Certificate : Rs 500/- per certificate is to be paid by student if the request for change inname in certificate/DMC. (DD in the favour of Punjab State Board of Technical Education) payable of Chandigarh.

If any discrepancy noted in the Registration candidate information issued by PICTC, please inform the PICTC office within seven days else Rs. 200 per certificate to be borne by CAL-C

Transfer of Student :

Transfer of student from one centre to other center will be allowed after the approval of PICT as per the conditions :-

1. Transfer is allowed after the completion of current semester.
2. Student will submit application form to franchise centre with the name of new centre.
3. Application along with the fee of Rs 500/- as Transfer fee to be submitted to PICTC.
4. Fee for next semester will be paid to new centre.

Detailed Rules

Detailed rules regarding leave, attendance, use of library facilities, computer laboratories etc. will be made by the respective Authorised Training Centres.

Discipline

1. Students are required to observe the decorum while attending the programme.
2. All the rules applicable for a centre, use of computers and other infrastructural facilities and materials will have to be observed by the students.
3. Students found violating the rules may be disallowed to continue and his/her admission can be cancelled without any claim of the fee paid. to the CAL-C Centre

2. It is not obligatory on the Punjab Infotech to offer training on the modified/updated programmes to the students who have registered for an earlier version of the programme.

Right to Amend Rules

The CAL-C HO reserves the right to add / delete / change / amend the syllabi, course structure, examination system, rules and regulations wherever considered necessary and appropriate without any prior notice. The students are advised to go through the website frequently where all circulars and important information are updated from time to time. Promulgation of any such information on the website in the form of circulars / notices is considered to be adequate.

Jurisdiction

All the disputes relating to the CAL-C programs and activities are subject to Chandigarh, India jurisdiction only.

General

1. The CAL-C HO reserves the right to update the programme through the change in methodology, contents & structure from time to time.

SOFTWARE PROGRAMS



Fee Structure

SOFTWARE COURSES

Course Name	Course Code	Amount	Page No.
Post Graduate Diploma in Computer Application(PGDCA)	PG	15000	16
Diploma in Information Technology (DIT)	A02	14000	17
Diploma in E-Commerce	A04	18000	17
Certificate Course in Information Technology	A05	12000	18
Diploma in Computer Applications (DCA)	A06	14000	19
Diploma in Financial Accounting (DFA)	A07	14000	19
Certificate Course in Computer Applications	B01	7000	20
Certificate Course in JAVA & Advance JAVA Programming	B02	8000	20
Certificate in Programming Excellence through PHP & MYSQL	B03	6000	20
Diploma in web Technology	B07	12000	21
Certificate Course in E-Accounting	B08	7000	21
Certificate Course in Computer Fundamental & Office Application	C01/C01F	3500	21
Certificate Course in Web Designing	C02	5000	22
Certificate Course in Financial Accounting	C03	2500	22
Certificate Course in 'C' Programming	C06	4000	22
Certificate Course in C++ Programming	C07	4000	22
Certificate Course in JAVA Programming	C08	6000	22
Certificate Course in Desk Top Publishing	C12	2500	23
Certificate Course in AutoCAD	C13	4500	23
Certificate Course in Data Entry Operations	C14	4000	23
Certificate Course in Computer Operations & Applications	C15	5000	24
Certificate Course in Business First Portal	C16	5000	24
Certificate Course on Goods & Service Tax (GST)	C18	5000	25
Certificate Course in Digital Marketing	C19	4000	25
Certificate Course in Web Designing using HTML	C20	4000	25
Certificate Course in Computer Fundamental & Office	C21/C21F	5000	26
Certificate Course in Python	C22	4000	26
Certificate Course in Programming Excellence through VB.Net & ASP.Net	C23	6000	26
Certificate Course in Programming Excellence through C# with	C24	6000	26
Rapid Computer Program-I	RP1	1000	27
Rapid Computer Program-II Web Designing	RP2	1500	27
Rapid Computer Program-II Computer Programming	RP2	1500	27
CAL-C IELTS Advantage	CIA	3500	27

(Examination for C01/C01F/C14/C15 & C21/C21F will be conducted monthly which comprises of 2 objective type theory papers of 70 marks each & practical of 60 marks, with exam fee of Rs. 200/-)

Sr. No.	Examinations Fee	Fee in Rs(INR)
1.	Diploma Courses (per Semester)	500
2.	Certificate Courses for C01/C01F/C14/C15/C16/C18/C21/C21F	200
3.	Re-appear (per subject)	250
4.	Exam Fee (PGDCA COURSE) - Per Semester	1000

Detailed Syllabi may be downloaded from website www.punjabinfotech.in
Taxes as applicable
Fees once paid is non refundable
Examination for C01/C01F/C14/C15 & C21/C21F will be conducted monthly which comprises of 2 objective type theory papers & practical, with exam fee of Rs. 200/-
for C16 & C18 exam contact the respective centre.
If appears in more than two subject LTC complete semester fee to be paid.
(Windows 7 or Latest & MS Office 2010 or higher version is included in syllabus.)

Programs

LONG TERM COURSES

Post Graduate Diploma in Computer Application (PGDCA or PG)

Eligibility : Graduate

Fee : 15,000/-

Semester : I, 480 Hrs

Duration : 12 Months (960 hrs)

SUBJECT CODE	SUBJECT	TOPICS	T	P	Total Dur. Hrs.	Theory Exam	Practical Exam	Exam Dur.
PG 01	Computer Fundamentals	Computer fundamentals, Operating System, Storage Management, MS-Office	48	64	112	100	50	3
PG 02	Programming using C and Data Structures	Fundamentals, Arrays & Pointers, Data Structures	48	64	112	100	50	3
PG03	OOP's with C++	Data Types, Operates, Classes & Objects	48	64	112	100	50	3
PG04	Web Technology - I (HTML, Core Java and Java Script)	HTML, Javascript, Communication Skills	48	64	112	100	50	3
PG05	Generic Skills	Office Management, Communication Skills	32	-	32	100		3
Semester Total			224	256	480	500	200	

Semester : II, 480 Hrs

SUBJECT CODE	SUBJECT	TOPICS	T	P	Total Dur. Hrs.	Theory Exam	Practical Exam	Exam Dur.
PG06	Computer Networks	OSI Layers, Switching, LAN	48	16	112	100	50	3
PG07	RDBMS	RDBMS, SQLPWS	48	64	112	100	50	3
PG08	Web Technology - II (Introduction to .NET Technologies, .NET Framework, ASP.NET)	.Net, ASP .Net, ADO .Net	48	64	112	100	50	3
PG09	SE and Project Management	Software Requirement Analysis & Specification. Planning of software project	48	-	48	100	-	3
PG10	MIS	MIS, Decision making, ERP	32	-	32	100	-	3
PG11	Project Work	Project Work	-	112	112		150	3
Total			224	256	480	500	300	

- Examination will be conducted by Punjab State Board of Technical Education (PSBTE) & certificates will be provided to the qualified students by PSBTE
- Registration fee to be charged Rs. 1000/- from student & to be deposited with Punjab Infotech.
- Exam Fee is Rs.1000/- Per Semester, Rs500/- Per subject for re appearing
- Registration in PGDCA course is for Punjab CAL-C Centers only
- PGDCA (Only in Punjab)

Diploma in Information Technology (DIT) (A02)

Eligibility : 10+2

Fee : 14,000/-

Semester : I, 275 Hrs

Duration : 12 Months (600 hrs)

SUBJECT CODE	SUBJECT	TOPICS	T	P	Total Dur. Hrs.	Total Marks	Exam Dur.
A02- 01	Computer Fundamentals	Computer Fundamentals Operating System: DOS, UNIX,	60	40	100	100	3
A02- 02	Office	Word, Excel, Power Point	35	65	100	100	3
A02- 03	Access	DBMS Concepts, Design of database, Fill exposure of Access	30	45	75	100	3
Total			125	150	275	300	

Semester : II, 325 Hrs

SUBJECT CODE	SUBJECT	TOPICS	T	P	Total Dur. Hrs.	Total Marks	Exam Dur.
A02- 04	Concepts of Networking	Introduction to Computer Networking Windows 2000 or higher	50	25	75	100	3
A02- 05	Web Programming	HTML, Front Page & DHTML	40	60	100	100	3
A02- 06	Computer Programming using C++	Concepts of OOP's & Programming using C++ Language	40	60	100	100	3
A02- 07	Project & Viva	Using any Language of the course	-	50	50	100	-
Total			130	195	325	400	

Diploma in E-Commerce (A04)

Eligibility : 10+2

Fee : 18,000/-

Semester : I, 280Hrs

Duration : 12 Months (600 Hrs.)

SUBJECT CODE	SUBJECT	TOPICS	T	P	Total Dur. Hrs.	Total Marks	Exam Dur.
A04- 01	Internet Fundamentals and E-Business, SEO, Payment Gateway Steps	Basics of Internet Concepts, E-Commerce Framework, E-Commerce Security Issue, Introduction to WAP, SEO, Payment Gateway steps	20	-	20	-	-
A04- 02	E-Web Publishing & Scripting (Client Side Scripting)	HTML using Frontpage, DHTML, Introduction to XML Scripting Using Java / VB	40	60	100	100	3
A04- 03	Web Graphics & Multimedia Development	Adobe Photo shop, Corel Draw	20	40	60	100	1* (*Practical)
A04- 04	Networking & Communication Technology	Networking Basics, Installing & Configuring the Network with Win2003/2008, Server Administration Tools	60	40	100	100	3
Total			140	140	280	300	

Semester :II, 320 Hrs

SUBJECT CODE	SUBJECT	TOPICS	T	P	Total Dur. Hrs.	Total Marks	Exam Dur.
A04-05	Oracle	RDBMS using MYSQL	45	55	100	100	3
A04-06	Application Programming	Programming using C#.net	40	60	100	100	3
A04-07	Web Application Development using Java Programming (Server Side Scripting)	Basic's of OOP's concepts & C++, Core Java programming using J2EE Framework, Java Applets & Swings, JDBC, Java Servlets, Java Beans, Introduction to JSP, EJB	40	60	100	100	3
A04-08	Project & Viva	Using Web / Application Development with case study		20	20	100	1
Total			125	195	320	400	

Certificate Course in Information Technology (A05)

Eligibility : 10th

Fee : 12,000/-

Semester I,290 Hrs

Duration :12 Months (615 hrs)

SUBJECT CODE	SUBJECT	TOPICS	T	P	Total Dur. Hrs.	Total Marks	Exam Dur.
A05-01	Fundamentals of information Technology Operating System	Fundamentals of information Technology, computers and Operating System.	65	35	100	100	3
A05-02	Office	Word, Excel, Power Point Introduction to Internet and MS Outlook	40	60	100	100	3
A05-03	Access	DBMS using ACCESS	45	45	90	100	3
Total			150	140	290	300	

Semester II, 325 Hrs

SUBJECT CODE	SUBJECT	TOPICS	T	P	Total Dur. Hrs.	Total Marks	Exam Dur.
A05-04	Computer Programming	Introduction to Programming & Computer Language (C++)	50	50	100	100	3
A05-05	Web Development	Web development using HTML, JAVA Script	50	50	100	100	3
A05-06	Project & Viva	Project on Web Development	-	100	100	100	1
A05-07	Communication Skills in English	Communication Skills in English	25	-	25	-	-
Total			125	200	325	300	

Course Name : Diploma in Computer Applications (DCA) (A06)**Eligibility : 10+2****Fee : Rs 14,000/-****Semester 1: 275 Hrs**

SUBJECT CODE	SUBJECT	TOPICS	T	P	Total Dur. Hrs.	Total Marks	Exam Dur.
A06-01	Computer Fundamentals	Computer Fundamentals, Operating System: DOS, UNIX	60	40	100	100	3
A06-02	MS Office	Ms Word, Ms Excel, Ms Power Point	35	65	100	100	3
A06-03	Data Base Management System	DBMS Concept, Design of database, Fill exposure of Access	30	45	75	100	3
Total			125	150	275	300	

Semester II, 325 Hrs

SUBJECT CODE	SUBJECT	TOPICS	T	P	Total Dur. Hrs.	Total Marks	Exam Dur.
A06-04	Programming Language	Programming Language C++, Practical on C ++ Programming, Practical on Application Program	40	60	100	100	3
A06-05	Java	Fundamentals of Oops, Core Java, Project Java	40	35	75	100	3
A06-06	Internet and Web Page Designing	Internet and Web Page Designing, World Wide Web (WWW), Web Publishing, HTML 5	40	60	100	100	3
A06-07	Project & Viva	Using any Language of the course	-	50	50	100	-
Total			120	205	325	400	

Course Name : Diploma in Financial Accounting (DFA) (A07)**Eligibility : 10+2 (with knowledge of Maths)****Fee : Rs 14,000/-****Semester I, 275 Hrs**

SUBJECT CODE	SUBJECT	TOPICS	T	P	Total Dur. Hrs.	Total Marks	Exam Dur.
A07-01	Computer Fundamentals	Computer Fundamentals, Operating System: DOS, UNIX	60	40	100	100	3
A07-02	MS Office	Ms Word, Ms Excel, Ms Power Point	35	65	100	100	3
A07-03	Data Base Management System	DBMS Concept, Design of database, Fill exposure of Access	30	45	75	100	3
Total			125	150	275	300	

Semester II, 325 Hrs

SUBJECT CODE	SUBJECT	TOPICS	T	P	Total Dur. Hrs.	Total Marks	Exam Dur.
A07-04	Fundamentals of Accounting	Introduction of Accounting, Equation, Journal, Ledger, Trial Balance, Cash Book etc	60	40	100	100	3
A07-05	Tally Prime 2.0	Company Creation, Vouchers, Balance sheet, Inventory, Statutory Taxation, GST, TDS, TCS etc	40	60	100	100	3
A07-06	Tally Payroll	Payroll, Income Tax, HR (Payroll)	40	35	75	100	3
A07-07	Project & Viva	Using Accounting or Tally of the course	-	50	50	100	-
Total			140	185	325	400	

Certificate Course in Computer Applications (B01)

Eligibility : 10+2

Fee : 7,000/-

Duration : 6 Months (275hrs)

SUBJECT CODE	SUBJECT	TOPICS	T	P	Total Dur. Hrs.	Total Marks	Exam Dur.
B01-01	Computer Fundamentals	Computer Fundamentals, Operating System: DOS, UNIX, Windows	60	40	100	100	3
B01-02	Office	Word, Excel, Power Point	35	65	100	100	3
B01-03	Access	DBMS Concepts, Design of database, Fill exposure of Access	30	45	75	100	3
Total			125	150	275	300	

Certificate Course in JAVA & Advance JAVA Programming (B02)

Eligibility : 10+2 with relevant basic knowledge

Fee : 8,000/-

Duration : 6 Months (210 Hrs)

SUBJECT CODE	SUBJECT	TOPICS	T	P	Total Dur. Hrs.	Total Marks	Exam Dur.
B02-01	Programming Fundamentals of C#	Fundamentals of C# Basis	10	15	25		
B02-02	Core Java Programming Applets	Fundamentals of OOP's, Core Java,	40	70	110	100	3
B02-03	Advance Java	JDBC, RMI, Servlets, JSP, Beans, EJB	20	35	55	100	3
B02-04	Project Work: Development of Web Application	Using Core & Advance Technologies of Java & Oracle / SQL	-	20	20	100*	
Total			70	140	210	300	

SHORT TERM COURSES

Certificate in Programming Excellence through PHP & MYSQL (B03)

Eligibility : 10+2 with relevant Basic Knowledge

Fee : 6,000/-

Duration : 3 Months (160 Hrs)

SUBJECT CODE	SUBJECT	T	P	Total Dur. Hrs.
B03-01	Programming using PHP	35	50	85
B03-02	MYSQL	15	25	40
B03-03	LINUX	5	10	15
B03-04	Project Work: Development of Web Application	-	20	20
Total		55	105	160

Diploma in Web Technology (B07)

Eligibility : 10+2 Pass

Fee : 12000/-

Semesters: One, Examination : Feb/Aug

Duration : 6 Months (315 Hrs)

SUBJECT CODE	SUBJECT	T	P	Total Dur. Hrs.	Total Marks	Exam Dur.
B07-01	Windows Operating System & Programming Fundamentals	10	20	30	100	3
B07-02	MySQL	10	10	20	100	3
B07-03	C# and ASP.Net	20	30	50	100	3
B07-04	PHP	30	70	100	100	3
B07-05	Project Work	35	80	115	100	
Total		105	210	315	500	

Course Name : Certificate Course in E-Accounting (B08)

Eligibility : 12th (with knowledge of Maths)

Fee : Rs 7,000/-

Duration : 6 Months (300 Hours)

SUBJECT CODE	SUBJECT	TOPICS	T	P	Total Dur. Hrs.	Total Marks	Exam Dur.
B08-01	MS-Windows & MS-Office	Windows, Word, Excel, PowerPoint	35	65	100	100	3
B08-02	Fundamentals of Accounting	Introduction of Accounting, Equation, Journal, Ledger, Trile Balance, Cash Book etc.	60	40	100	100	3
B08-03	Tally Prime	Company Creation, Vouchers, Statutory Taxation, GST, TGS, TCS etc.	40	60	100	100	3
B08-04		Practical work				100	
Total			135	165	300	400	

Certificate Course in Computer Fundamental & Office Application (C01, C01F for Govt. Employee only on Fast Track Mode in one month)

Eligibility : 10th

Fee : 3,500/-

Duration : 3 Months (120 Hrs)

SUBJECT CODE	SUBJECT	TOPICS	T	P	Total Dur. Hrs.
C01-01	Computer Fundamentals & Personal Information System (Outlook express)	Computer Architecture and Fundamentals	07	-	07
		Operating Systems & DOS, WINDOWS, O.S.	15	25	40
		Internet, Essentials, Email & Outlook Express	06	15	21
			28	40	68
C01-02	Word Processing, Spread Sheets, Presentation Graphics and PC Data Bases	Office Package			
		Word	10	15	25
		Excel	05	15	20
	Power Point	02	05	07	
			17	35	52
Total			45	75	120

Certificate Course in Web Designing (C02)

Eligibility : 10th

Fee : 5,000

Duration : 3 Months (135 Hrs)

SUBJECT CODE	SUBJECT	TOPICS	T	P	Total Dur. Hrs
C02-01	Web Technologies	HTML (Using Front Page), DHTML Java A/ VB Script Web Graphics Concepts, GIF Animator,	15	30	45
C02-02	Desk Top Publishing Tools (Any two tools)	Adobe Photoshop, Corel Draw, Macromedia Dreamweaver, Flash	15	30	45
C02-03	Project Work	Web Site Development using all the Web Development and Publishing Tools	15	30	45
Total			45	90	135

Certificate Course in Financial Accounting (C03)

Eligibility : 10th

Fee : 2,500/-

Duration : 3 Months (120 Hrs)

SUBJECT CODE	SUBJECT	TOPICS	T	P	Total Dur. Hrs.
C03-01	Computer Fundamentals	Computer Fundamentals DOS, WINDOWS	15	30	45
C03-01	Financial Accountancy	Using any Financial Accounting Package (Tally)	15	30	45
Total			45	75	120

Certificate Course in 'C' Programming (C06)

Eligibility : 10th

Fee : 4,000/-

Duration : 10 weeks (80 Hrs)

SUBJECT CODE	SUBJECT	TOPICS	T	P	Total Dur. Hrs.
C06-01	Programming using C Language	Language & Programming Basics Fundamentals of Programming using 'C' Language	35	45	80
Total			35	45	80

Certificate Course in C++ Programming (C07)

Eligibility : 10th

Fee : 4,000/-

Duration : 10 Weeks (100 Hrs)

SUBJECT CODE	SUBJECT	TOPICS	T	P	Total Dur. Hrs.
C07-01	Programming using C++ Language	Language & Programming Basics Basic Concepts of OOP's, Programming using C++	50	50	100
Total			50	50	100

Certificate Course in JAVA Programming (C08)

Eligibility : 10th

Fee : 6,000/-

Duration : 12 Weeks (100 Hrs)

SUBJECT CODE	SUBJECT	TOPICS	T	P	Total Dur. Hrs.
C08-01	Web Programming using JAVA	Basic Concepts of OOP's, Programming using JAVA, AWT, Applets, Swings	40	60	100
Total			40	60	100

Certificate Course in Desk Top Publishing (C12)

Eligibility : 10th

Fee : 2,500/-

Duration : 3 Months (110 Hrs)

SUBJECT CODE	SUBJECT	TOPICS	T	P	Total Dur Hrs.
C12-01	Computer Fundamentals	Computer Fundamentals DOS, WINDOWS	10	20	30
C12-02	Desk Top Publishing Tools	Adobe Photoshop, Page Maker, Corel Draw	30	50	80
Total			40	70	110

Certificate Course in AutoCAD (C13)

Eligibility : 10th

Fee : 4,500/-

Duration : 10 weeks (90 Hrs)

SUBJECT CODE	SUBJECT	TOPICS	T	P	Total Dur. Hrs.
C13-01	Computer Fundamentals	Computer Fundamentals, DOS, WINDOWS	10	20	30
C13-02	AutoCAD	AutoCAD, Advance AutoCAD	20	40	60
Total			30	60	90

Certificate Course in Data Entry Operations (C14)

Eligibility : 10th

Fee : 4,000/-

Duration : 3 Months (150Hrs)

SUBJECT CODE	SUBJECT	TOPICS	T	P	Total Dur.Hrs.	
C14- 01	Computer Fundamentals & Personal Information System (Outlook express)	Computer Architecture and Fundamentals	07	-	07	
		Operating Systems & DOS,	12	25	37	
		Windows 7.0 O.S.				
		Internet Essentials, Email & Outlook Express	06	15	21	
			25	40	65	
C14- 02	Word Processing, Spread Sheets, Presentation Graphics and PC Data Bases	Office Package				
		Word	05	15	20	
		Excel	10	15	25	
		Power-Point	02	05	07	
		Access	08	15	23	
			25	50	75	
C14- 03	Office Services and Automation	English Typing Software, Data Entry Practice (Numeric & Alpha Numeric) on typing software	-	08	08	
		Presentation & Communications skills	-	02	02	
					-	10
Total			50	100	150	

Certificate Course in Computer Operations & Applications (C15)

Eligibility : 10th

Fee : 5,000/-

Duration : 4Months (200Hrs)

SUBJECT CODE	SUBJECT	TOPICS	T	P	Total Dur. Hrs.
C15- 01	Computer Fundamentals & Personal Information System	Computer Architecture and Fundamentals	07	-	07
		Operating Systems & DOS, MS Windows 7.0 O.S.	12	25	37
		Internet Essentials, Email & Outlook Express	06	15	21
		Total	25	40	65
C15- 02	Word Processing, Spread Sheets & Presentation Graphics	Office Package			
		Microsoft Word	05	15	20
		Microsoft Excel	10	15	25
		Microsoft Power-Point	05	05	10
Total	20	35	55		
C15- 03	DTP Tools	Document Design & Essentials of Printing Technology using Corel Draw	10	20	30
C15- 04	Computerised Financial Accounting and Tally	Financial Accounting & Inventory Control using Tally	20	30	50
Total			75	125	200

Certificate Course in Business First Portal (C16)

Eligibility : Passed Graduation in any field with minimum 50% marks & having functional/basic knowledge of computer & passed punjabi at matriculation level or equivalent standard.

Fee : 5,000/-

Duration : (50 Hrs)

Module Code	Subject	Contents	Theory (Hrs)	Practical (Hrs)	Total
C16	MS-Office & Basics of Internet	- MS-Office	03	03	06
		- Photo Editing Softwares			
		- Internet Essentials			
	Basic Information about Regulatory Clearances Required		05	04	09
	Basic Information about Fiscal Incentives & its Common Application Form		04	04	08
	Common Application Form (CAF)		10	12	22
	Business Communication Skills	- Verbal & Non-verbal Communication - Telephone etiquette	02	02	04
	Business First User Manual	- Summarize Business First User Manual	01	00	01
Total			25	25	50

Objective type paper of 50 marks
Passing Marks : 60%

Certificate Course on Goods & Service Tax (GST) (C18)

Eligibility : 10+2 Pass with knowledge of Accounting
 Fee : 5000/-

Duration : 1 Month (50 Hours)

SUBJECT CODE	SUBJECT	T	P	Total Dur. Hrs.
C18-01	Basic of Accounting Introduction to GST. GST Concepts, Levy & Collection of GST, Payment of Tax & GST Returns, TDS & TCS, Refund of GST Accounts & Records & E-way Bill E-commerce Inspection Office & Penalties etc.	30	15	50
C18-02	Case Study & Practical	05		
Total		35	15	50

*Objective type theory paper of 70 marks, practical of 30 marks.

Course Name : Certificate Course in Digital Marketing (C19)

Eligibility : 10+2
 Fee : Rs 4,000/-

Duration : 3 Months (120 Hours)

SUBJECT CODE	SUBJECT	TOPICS	T	P	Total Dur. Hrs.
C19-01	Overview	Digital Marketing Overview of Web Design & Development Search Engine Optimization Google Search Console E-mail Marketing	20	30	50
C19-02	SEO	WordPress Google Analytics Facebook Marketing - Youtube Marketing Google Ads Rating of websites	20	50	70
Total			40	80	120

Course Name : Certificate Course in Web Designing using HTML (C20)

Eligibility : 10+2
 Fee : Rs 4,000/-

Duration : 3 Months (120 Hours)

SUBJECT CODE	SUBJECT	TOPICS	T	P	Total Dur. Hrs.
C20-01	Overview of websites	Website Structure and Hosting, Basics of HTML	20	30	50
C20-02	Creating websites using its attributes	Creating stylish Websites, CSS Basics & Properties Creating HTML Forms, Creating Web Applications, Frames and its attributes, Layout Designing	10	30	40
C20-03	-	Intro to Programming with the use of JavaScript JavaScript Program & Testing, J Query, Introduction to boot strap	10	20	30
Total			40	80	120

Course Name : Certificate Course in Computer Fundamental & Office Automation (C21, C21F for Govt. Employee only on Fast Track Mode in one month)

Eligibility : 10th

Fee : Rs 5,000/-

Duration : 3 Months (120 Hours)

SUBJECT CODE	SUBJECT	TOPICS	T	P	Total Dur. Hrs.
C21-01	Computer Fundamentals & Personal Information System (Outlook express)	Computer Architecture and Fundamentals Operating Systems & MS-DOS, MS Windows OS. Internet Essentials, Email & Outlook Express	20	30	50
C21-02	Word Processing, Spread Sheets, Presentation Graphics and PC Data Bases	Ms- Office Package 2010 & above MS- Word, Excel & Powerpoint	15	30	45
C21-03	Typing- English & Punjabi GPT Overview	Overview of Chat GPT, Typing (English & Punjabi) Asees font	05	20	25
Total			40	80	120

Course Name : Certificate Course in Python (C22)

Eligibility : 10+2

Fee : Rs 4,000/-

Duration : 3 Months (120 Hours)

SUBJECT CODE	SUBJECT	TOPICS	T	P	Total Dur. Hrs.
C22-01	Elementary Programming	Introduction, Conditional Statements, Looping, Control Statements, String Manipulation	10	15	25
C22-02	Python collections	Collections (Lists, Tuples, Dictionaries), Sets Functions Modules/Packages Input-Output Exception Handling	20	25	45
C22-03	Oops Concepts	OOPs concept, Regular expressions Overview of Database & GUI Programming	10	40	50
Total			40	80	120

Course Name : Certificate Course in Programming Excellence through VB.Net & ASP.Net (C23)

Eligibility : 10+2

Fee : Rs 6,000/-

Duration : 4 Months (200 Hours)

SUBJECT CODE	SUBJECT	TOPICS	T	P	Total Dur. Hrs.
C23-01	Oops Programming concepts	Programming Fundamentals of C#	10	15	25
C23-02	VB.Net	Introduction to Microsoft .NET Migrating to VB.NET	20	10	30
C23-03	ASP.Net	Exploring Visual Studio .NET & ASP. Net using Visual Basic .NET	40	55	95
C23-04	Project work	Project Work: Development of Desktop & Web Application using Database	-	50	50
Total			70	130	200

Course Name : Certificate Course in Programming Excellence through C# with ASP.Net (C24)

Eligibility : 10+2

Fee : Rs 6,000/-

Duration : 4 Months (200 Hours)

SUBJECT CODE	SUBJECT	TOPICS	T	P	Total Dur. Hrs.
C24-01	Concept of C# along with Microsoft.Net Framework	Programming Fundamentals of C# Introduction to Microsoft.Net	30	25	55
C24-02	Integration with ASP.Net	Programming C# with ASP.NET	40	55	95
C24-03	Project work	Project Work : Development of Web Application using database	-	50	50
Total			70	130	200

Rapid Computer Program- I (RP1)

Eligibility : 6th – 10th

Fee : 1,000/-

Duration : 4 weeks (30Hrs)

SUBJECT CODE	SUBJECT	T	P	Total Dur. Hrs
RP1-01	Introduction to IT & Computers	4	6	10
RP1-02	Office 2010 /Higher	4	6	10
RP1-03	Internet Fundamentals	-	5	5
RP1-04	Personality development on attitude and habits	-	5	5
Total		8	22	30

Rapid Computer Program- II Web Designing (RP2)

Eligibility : 10th-12th

Fee : 1,500/-

Duration : 5 weeks (45Hrs)

SUBJECT CODE	SUBJECT	T	P	Total Dur. Hrs
RP2-01	Basic of Computers	4	6	10
RP2-02	Internet Fundamentals	2	3	5
RP2-03	HTML	5	10	15
RP2-04	DHTML	3	10	13
RP2-05	Introduction to XML	1	1	2
Total		15	30	45

Rapid Computer Program- II Computer Programming (RP2)

Eligibility : 10th- 12th

Fee : 1,500/-

Duration : 5 Weeks (45 Hrs)

SUBJECT CODE	SUBJECT	T	P	Total Dur. Hrs
RP2-01	Basic of Computers	4	6	10
RP2-02	Basic of Computers Programming	5	-	5
RP2-03	Computer Programming using 'C' Language	10	20	30
Total		19	26	45

CAL-C IELTS Advantage (CIA)

Eligibility: 10+2

MODULE	DURATION	PURPOSE / OBJECTIVE	Fee
Module I	60	Essential for assimilation of Software/ Hardware courses at CAL-C Centre	Rs.2, 000/- (to be exempted if student opts for CAL-C course of six months or higher duration or Module-II before completion of Module-I)
Module II (IELTS)	120	· Essential for IELTS (General & Academics) Exam · A candidate after this course will be fully trained to understand IELTS exam	Rs.3, 500/-

This course is for software & Hardware centres.

Note : 60Hrs Spoken English Module-I Training Program will be given to all 6 months and above course students free of cost

Terms & Conditions :

1. Admissions to all courses will be made strictly on the basis of eligibility or terms.
2. Every student shall pay the fee as specified in advance at the time of admission in cash or DD.
3. Fee will be paid in lump sum semester wise. In certain cases, it may be paid in installments at the discretion of the Authorised Training Centre. Rules regarding payment of fees in installments will be drawn up by the centres themselves.
4. Fee once paid is not refundable. However, the balance of fees will be transferred to the new ATC in case the migration of a student is permitted to that ATC.
5. In case of revision in fee structure by CAL-C HO, the student will be bound to pay the balance of the fees to the ATC.
6. 10% Concession in fee is admissible in case of candidates belonging to SC / ST categories & Physically handicapped persons subject to procedures laid down by the PICTCL & furnishing of evidence of relevant documents. This concession will also extend to Govt. Employees (State / Central.)
7. Evaluation is based on the project work & final exams.
8. A student will have to qualify each written exam with 40% marks.
9. Detailed Syllabi may be downloaded from website www.punjabinfotech.in, Also the students can view the website for any details.
10. Taxes as applicable

HARDWARE PROGRAMS



Fee Structure

HARDWARE COURSES

Fee Structure	Course Code	Fee in Rs	Page No.
CAL-C Certified Computer Hardware & Networking Professional	H01	18,000	30
CAL-C Certified System Administrator	H02	12,500	31
CAL-C Certified Chip Level Troubleshooting	H03	10,000	31
CAL-C Certified Network Engineer	H04	12,500	32
Advance Computer Hardware & Networking Professional	H05	20,000	32
Certificate Course in Computer Maintenance & Networking	H06	18,000	33
PC Assembling and Troubleshooting	STC 1	3,000	34
Monitor Diagnostic and Servicing	STC 2	2,000	34
Printer Diagnostic and Servicing	STC 3	2,000	34
Networking with Windows NT	STC 4	2,500	35
Linux Networking	STC 5	2,000	35
Windows 2003	STC 6	2,500	35
Certificate in Cell Phone Servicing and Troubleshooting	CCST	10,000	35

Sr. No.	Examinations Fee	Fee in Rs(INR)
1.	Diploma Courses (per Semester)	500
2.	Re-appear (per subject)	250

Detailed Syllabi may be downloaded from website www.punjabinfotech.in

Taxes as applicable

Fees once paid is non-refundable

Examination System : (Hardware Courses)

- Examination will be held for long term courses only.
- Participation certification will be given to the students enrolled under short term courses.

Programs

LONG TERM COURSES

Diploma / Advance Diploma / Certificate Courses

CAL-C Certified Computer Hardware & Networking Professional (H01)

Eligibility: Class 10th Pass / and above.

Fee: 18,000/-

Semester I, 350 hrs

Duration: 12 Months (550 hrs.)

SUBJECT CODE	SUBJECT	TOPICS	T	P	Total Dur. Hrs.	Total Marks	Exam Dur
H01-1.1	Basics (Analog & Digital Electronics)	Fundamental of Electronics, Passive Components, Logic Circuits and Gates, Logic Gates and Semi Conductor, Memories	55	45	100	100	3
H01-1.2	Computer Application & Hardware	Microprocessor, Motherboard, Buses, Operating Systems	105	145	250	100	3
	Practical -I					100	
		Total	160	190	350	300	

Semester II, 200hrs

SUBJECT CODE	SUBJECT	TOPICS	T	P	Total Dur. Hrs.	Total Marks	Exam Dur
H01-2.1	Network Technologies	N/W Essentials, Basics of Network Administration of Windows 2000/2003, Active Directory, Managing Domain, Users	90	110	200	100	3
	Practical -2					100	
		Total	90	110	200	200	

CAL-C Certified System Administrator (H02)

Eligibility: 3 years Diploma / B.E. in E & TC or CS or IT / final semester students of B.E.

Fee: 12,500/-

Duration: 6 Months (260 hrs)

SUBJECT CODE	SUBJECT	TOPICS	T	P	Total Hrs.	Dur.	Total Marks	Exam Dur
H02-1.1	Computer Application & Hardware	Microprocessor, Motherboard, Memory, Assembling	30	50	80		100	3
H02-1.2	Network Technologies	N/W Essentials, Basics of Network Administration of Windows 2000/2003	65	115	180		100	3
	Practical						100	
		Total	95	165	260		300	

CAL-C Certified Chip Level Troubleshooting (H03)

Eligibility: 10th

Fee: 10,000/-

Duration: 6 Months (260 hrs)

SUBJECT CODE	SUBJECT	TOPICS	T	P	Total Hrs.	Dur.	Total Marks	Exam Dur
H03-1.1	BASICS (Analog Electronics) Digital Electronics	Fundamentals of Electronics Semiconductor Logic Circuits and Applications Flip-flops, Mux, Demux		25	35		60	100 3
H03-1.2	PC Hardware	Microprocessor		15	35		50	100 3
H03-1.3	Troubleshooting of Electronic Devices	Power Supplies Motherboard, UPS & Mobile Repair and Troubleshooting		50	100		150	100 3
	Practical							100
		Total		90	170		260	400

CAL-C Certified Network Engineer (H04)

Eligibility: 3 years Diploma / B.E. in E & TC or CS or IT / final semester students of B.E.

Fee: 12,500/-

Duration: 6 Months (300 hrs)

SUBJECT CODE	SUBJECT	TOPICS	T	P	Total Hrs.	Dur.	Total Exam Marks	Dur
H04-1.1	Networking Essentials	Overview of N/W Components, Transmission Media	15	15	30		100	3
H04-1.2A	Windows 2000/2003	Microsoft Windows 2003 Server	60	160	220		100	3
	OR							
H04-1.2B	Linux	Pre-Installation User Management Mounting Utilities, System Configuration	80	140	220		100	3
H04-1.3	Wide Area Networks	WAN Protocols & Technologies. Cisco N/W Design Subnetting & VLSM	20	30	50		100	3
	Practical						100	
		Total		-	-	300	400	

Advance Computer Hardware & Networking Professional (ACHNP) (H05)

Eligibility: 12th pass and above / CAL-C Certified Computer Hardware Networking Professional (H01)

Fee: 20,000/-

Semester I, 275 hrs

Duration: 12 Months (550 hrs)

SUBJECT CODE	SUBJECT	TOPICS	T	P	Total Hrs.	Dur.	Total Exam Marks	Dur
H05-1.1	IT Fundamentals & Operating Systems	Computer System Unix Editor Introduction to Linux Operating System working with files	30	30	60		100	3
H05-1.2	Basic Electronics & Microprocessor	Fundamental of Electronics Semi Conductor Relays and Switches	35	35	70		100	3
H05-1.3	PC Assembling & Troubleshooting	Input & Output Devices Operating System Installation Installation of Devices & Peripherals	30	50	80		100	3
H05-1.4	Programming in C/C++	Operators and Expressions Arrays Overview of C++	25	40	65		100	3
		Total	120	155	275		400	

Semester II, 275 hrs

SUBJECT CODE	SUBJECT	TOPICS	T	P	Total Dur. Hrs.	Total Marks	Exam Dur
H05-2.1	Network Essential	Networking Devices Cabling Network Protocols	25	30	55	100	3
H05-2.2	Windows 2000/2003 Administration	Server Management Internet Technologies	30	60	90	100	3
H05-2.3	LINUX Administration	LINUX Server Administration Installation of Devices & Peripherals	25	45	70	100	3
H05-2.4	Database Administration (MS Office & Access)	Introduction to databases, DBMS and RDBMS understanding Databases Creating Tables	25	35	60	100	3
Total			105	170	275	400	

Certificate Course in Computer Maintenance & Networking (CCCMN) (H06)**Eligibility:** 10th pass and above**Fee:** 18000/-**Semester I, 275 hrs****Duration:** 12 Months (550 hrs)

SUBJECT CODE	SUBJECT	TOPICS	T	P	Total Dur. Hrs.	Total Marks	Exam Dur
H06-1.1	Basic Electronics	Fundamental of Electronics Semiconductor SMPS	40	45	85	100	3
H06-1.2	Chip Level Repairing	Motherboard Laptop, Monitor, TFT	40	50	90	100	3
H06-1.3	PC Maintenance & Troubleshooting	Microprocessor Memory Assembling and CMOS	35	65	100	100	3
Total			115	160	275	300	

Semester II, 275 hrs

SUBJECT CODE	SUBJECT	TOPICS	T	P	Total Dur. Hrs.	Total Marks	Exam Dur
H06-2.1	Network Essentials	Network Devices Topology Network Protocols	45	45	90	100	3
H06-2.2	Windows 2000/2003	Server Installation Managing Server System Management	40	55	95	100	3
H06-2.3	LINUX Administration	Introduction of LINUX System Management	42	48	90	100	3
Total			127	148	275	300	

Short Term Programs

PC Assembling and Trouble Shooting (STC 1)

Eligibility : 10th

Fee : 3,000/-

Duration : 8 Weeks (80 Hrs)

MODULE	SUBJECT	TOPICS	T	P	Total Dur. Hrs.
1.1	PC Assembling and Trouble Shooting	Introduction, Working Principle of Devices, Serial Devices, Parallel Devices, Memory, Assembling, Dis-assembling of PC, Power Supply, CMOS Study, Software Installation Configuring Cards and Devices, Error Identification, Trouble Shooting, Case Study	20	60	80

Monitor Diagnostic and Servicing (STC 2)

Eligibility : 10th

Fee : 2,000/-

Duration : 4 Weeks (40Hrs)

MODULE	SUBJECT	TOPICS	T	P	Total Dur. Hrs.
1.1	Monitor Diagnostic and Servicing	Introduction, Study of Monochrome Monitors, Practical, Colour Monitors	10	30	40

Printer Diagnostic and Servicing (STC 3)

Eligibility : 10th

Fee : 2,000/-

Duration : 4 Weeks (40 Hrs)

MODULE	SUBJECT	TOPICS	T	P	Total Dur. Hrs.
1.1	Printer Diagnostic and Servicing	Printer Theory Impact Printers, Non-impact Printer, Printer Port, Servicing and Troubleshooting, Diagnostic Printer Faults Driver Installation, Case Study, FAQ (Frequently asked Questions)	10	30	40

Networking with Windows NT (STC 4)**Eligibility : 10th****Fee : 2,500/-****Duration : 4 Weeks (40 Hrs)**

MODULE	SUBJECT	TOPICS	T	P	Total Dur. Hrs.
1.1	Networking with Windows NT	Understanding Win NT Architecture, Installation, Configuration Tools, Networking Configuration, Services Configuration, Troubleshooting, Case Study	10	30	40

Linux Networking (STC 5)**Eligibility : 10th****Fee : 2,000/-**

Weeks

Duration : 4 Weeks (40 Hrs.)

MODULE	SUBJECT	TOPICS	T	P	Total Dur. Hrs.
1.1	Linux Networking	Understanding Linux Architecture, Installation, Configuration Tools, Networking, Configuration, Services Configuration, Troubleshooting, Case Study	10	30	40

Windows 2003 (STC 6)**Eligibility : 10th****Fee : 2,500/-****Duration : 4 Weeks (40Hrs)**

MODULE	SUBJECT	TOPICS	T	P	Total Dur. Hrs.
1.1	Windows 2003	Understanding Win 2003 Architecture, Installation, Configuration Tools, Networking Configuration, Services Configuration, Troubleshooting, Case Study	10	30	40

Certificate in Cell Phone Servicing and Troubleshooting (CCST)**Eligibility : 10th****Fee : 10,000/-****Duration : 4 Months (160 Hrs)**

MODULE	SUBJECT	TOPICS	T	P	Total Dur. Hrs.
1.1	Basic Electronics	Introduction	10	20	30
1.2	Telecommunication		10	20	30
1.3	Mobile Phone-I		30	70	100
		Total	50	110	160

Form No. _____



STUDENT REGISTRATION - CUM - ADMISSION FORM

Centre for Advance Learning in Computers (CAL-C)
Punjab Information & Communication Technology Corporation Limited
(A State Government Undertaking)

Regn. No. _____

CAL-C _____

(Authorised Training Centre)

Stream: Software Hardware

Course Applied for _____

Course Code: _____

Name (Mr./Ms.) _____

Father's Name _____

Father's Occupation (in case of minor) _____

Present Address _____

Vill./Town/City _____ Distt. _____

State _____ Pin Code _____

Phone No. _____ Mobile : _____

Aadhaar Card No. _____

E-mail : _____

Permanent Address _____

Vill. /Town/City _____ Distt. _____

State _____ Pin Code _____

Date of Birth _____ Age : _____

Sex : Male Female Third Gender Marital Status : Single Married Widow / Widower Divorced

Detail of Academic Qualifications : (Attach Attested Copies)

Examination	Year Passed	University/Board	% of Marks	Class/Division/Grade
10th				
10+2				
Graduation				
Post Graduation				
Others				

- Knowledge of Accounting for GST course (C18) - please Tick
- Knowledge of Maths for Accounting Courses (B08 & A07) - Please tick

Detail of any other Computer Course attended _____

Courses which have been previously attended CAL-C _____

Do you belong to SC/ST Physically Handicapped (Tick whichever is appropriate)

Govt. employee State/Centre Ex-Serviceman

Signature of applicant

Admitted Y/N

Date

D	D	M	M	Y	Y

Signature of Parents/Guardian

Date

I wish to Register for _____ at CAL-C Centre _____

(Course Name)

(City)

UNDERTAKING

I have gone through the prospectus and agree to abide by the rules and regulation of CENTRE FOR ADVANCE LEARNING IN COMPUTER TRAINING CENTRE as they exist at present or as amended from time to time. I hereby state that information provided above is true to the best of my knowledge.

Signature of parents/Guardian _____

(Signature of applicant)

Date : _____ Place : _____

For Office use only

EDN. QLN. OK Yes No

Photo Attested Yes No

Admitted Yes No

Registration No.

Session: Summer: (1st Feb to 31 July)

(for long terms course)

Session: Winter: (1stAug to 31 Jan)

I Have verified the qualification & other documents attached with the registration form from the original documents submitted by the student at the time of admission.

Date
D D M M Y Y

Signature (Centre Head)

INSTRUCTIONS TO APPLICANTS

- i) ELIGIBILITY: As per prospectus.
- ii) ADDRESS CHANGE/TRANSFER : Inform immediately quoting Registration Number.
- iii) Registration Fee: Rs. 100/- for each Course Payment should not be clubbed with requests for other documents like, Prospectus. For PGDCA course registration fee is Rs. 1000/-
- iv) Wherever (Place) is indicated, mark (✓) in the box applicable.
- v) Attach attested photocopies of certificates of education qualification (NOT of mark sheets).
- vi) Proof of equivalence in terms of Indian Universities should be sent in case registration is sought based on foreign qualifications.
- vii) Candidates denied registration should not refer to the attested photocopies of certificates of educational qualifications or other documents sent with the earlier registration form, while seeking registration again, with the submission of a fresh registration form, which should be complete in all respects, including all relevant enclosures.
- viii) Registration Forms complete in all respect, received after the last date fixed for receipt of such forms, for a particular examination, will not be considered for that examination, though Registration is open throughout the year for short term course & for long courses twice a year i.e. in summer & winter session.
- ix) Transfer of learning centre can be done only after the approval from Punjab Infotech.
- x) Admission / Exam dates can be changed at any time. Details can be viewed from www.punjabinfotech.in
- xi) Result can be viewed on Website of Punjab Infotech.

Form No. _____



Centre Copy

STUDENT REGISTRATION - CUM - ADMISSION FORM

Centre for Advance Learning in Computers (CAL-C)

Punjab Information & Communication Technology Corporation Limited

(A State Government Undertaking)

Regn. No. _____

CAL-C _____

(Authorised Training Centre)

Stream: Software Hardware

Course Applied for _____

Course Code: _____

Name (Mr./Ms.) _____

Father's Name _____

Father's Occupation (in case of minor) _____

Present Address _____

Vill./Town/City _____ Distt. _____

State _____ Pin Code _____

Phone No. _____ Mobile : _____

Aadhaar Card No. _____

E-mail : _____

Permanent Address _____

Vill. /Town/City _____ Distt. _____

State _____ Pin Code _____

Date of Birth _____ Age : _____

Sex : Male Female Third Gender Marital Status : Single Married Widow / Widower Divorced

Detail of Academic Qualifications : (Attach Attested Copies)

Examination	Year Passed	University/Board	% of Marks	Class/Division/Grade
10th				
10+2				
Graduation				
Post Graduation				
Others				

Knowledge of Accounting for GST course (C18) - please Tick

Knowledge of Maths for Accounting Courses (B08 & A07) - Please tick

Detail of any other Computer Course attended _____

Courses which have been previously attended CAL-C _____

Do you belong to SC/ST Physically Handicapped (Tick whichever is appropriate)

Govt. employee State/Centre

Ex-Serviceman

Signature of applicant

Admitted Y/N

Date

D	D	M	M	Y	Y

Signature of Parents/Guardian

Date

I wish to Register for _____ at CAL-C Centre _____

(Course Name)

(City)

UNDERTAKING

I have gone through the prospectus and agree to abide by the rules and regulation of CENTRE FOR ADVANCE LEARNING IN COMPUTER TRAINING CENTRE as they exist at present or as amended from time to time. I hereby state that information provided above is true to the best of my knowledge.

Signature of parents/Guardian _____

(Signature of applicant)

Date : _____ Place : _____

For Office use only

EDN. QLN. OK Yes No

Photo Attested Yes No

Admitted Yes No

Registration No.

Session: Summer: (1st Feb to 31 July)

(for long terms course)

Session: Winter: (1stAug to 31 Jan)

I Have verified the qualification & other documents attached with the registration form from the original documents submitted by the student at the time of admission.

Date
D D M M Y Y

Signature (Centre Head)

INSTRUCTIONS TO APPLICANTS

- i) ELIGIBILITY: As per prospectus.
- ii) ADDRESS CHANGE/TRANSFER : Inform immediately quoting Registration Number.
- iii) Registration Fee: Rs. 100/- for each Course Payment should not be clubbed with requests for other documents like, Prospectus. For PGDCA course registration fee is Rs. 1000/-
- iv) Wherever (Place) is indicated, mark (✓) in the box applicable.
- v) Attach attested photocopies of certificates of education qualification (NOT of mark sheets).
- vi) Proof of equivalence in terms of Indian Universities should be sent in case registration is sought based on foreign qualifications.
- vii) Candidates denied registration should not refer to the attested photocopies of certificates of educational qualifications or other documents sent with the earlier registration form, while seeking registration again, with the submission of a fresh registration form, which should be complete in all respects, including all relevant enclosures.
- viii) Registration Forms complete in all respect, received after the last date fixed for receipt of such forms, for a particular examination, will not be considered for that examination, though Registration is open throughout the year for short term course & for long courses twice a year i.e. in summer & winter session.
- ix) Transfer of learning centre can be done only after the approval from Punjab Infotech.
- x) Admission / Exam dates can be changed at any time. Details can be viewed from **www.punjabinfotech.in**
- xi) Result can be viewed on Website of Punjab Infotech.

Rules and Regulations

1. Every student seeking admission to the CAL-C Franchising Scheme (CFS) Course will register himself with the respective CAL-C. centre The Registration-cum-Admission Form is given in this prospectus. Only the original Registration-cum-admission Form as attached to the prospectus will be used. Purchase of prospectus is compulsory. However there is only Rs. 100/- registration fee.
2. On registration, each student will be issued a Registration number from PICTC Henceforth, this Registration No. will be used in all correspondence.
3. A student is allowed to register only for one course module at a time, as there may be clash of dates for examinations in case a student registers for multiple course concurrently. & if any clash is noted, Please inform office of PICTS in time.
4. The registration shall remain valid for one year for a short course and 2 years for a long course (one year duration) from the date of registration.
5. A duly registered student only, can appear for an examination. Two chances for reappear shall be given (within one year of completion of course) for courses of one year or less duration.
6. Registration is open twice a year for long terms course & throughout the year for short terms courses. However, the CAL-C HO holds examinations for long term course twice a year. The schedule for sending registration forms & exam forms is given on the last page of this booklet. On registration, a student will be issued with a Registration-cum-identity Card by Centre.
7. A student should always carry his Registration Identity Card with him while attending the Authorised Training Centre and the examination centre during examinations.
8. In case of loss Registration-cum-identity Card, a duplicate card can be obtained on payment of Rs. 50/- from Cal-C Centre.
9. Registration Card must be surrendered at the time of collection of examination certificate.
10. The Centre is entitled to refuse admission to anyone.

Event Calender For Admission & Examination

(for long term courses)

Note : If the last date for an event happens to be holiday/Sunday then the last date for submission would be deemed to be the next working day.

Activity	Winter Session Aug. Exams	Summer Session Feb. Exams
Semester Begins	1 st Feb.	1 st Aug.
Last Date of Receipt of Admission Forms without late fees	30 th April	31 st Oct.
Last Date of Receipt of Admission Forms with late fee of Rs. 500/-	31 st May (PGDCA) 20 th May	30 th Nov. 20 th Nov.
The Last Date of Submission of Examination Form by student	03 rd July	03 rd Jan
The Last Date for Submission of Examination Form by CAL-C Centre to Head Office	05 th July	05 th Jan
The Last Date for Submission of Examination Form (*) with late fee by student	08 th July	08 th Jan
The Last Date for Submission of Examination Form (*) with late fee by CAL-C Centre to Head Office	10 th July	10 th Jan
Roll Nos. to be dispatched to the CAL-C Centres	25 th July	25 th Jan
Examinations Start	2 nd week of Aug.	2 nd week of Feb.
Examinations End	3 rd week of Aug.	3 rd week of Feb.
IA & Project marks submitted to Head Office by CAL-C Centres sheets,	Alongwith Submission of Answer Attendance Sheet Project Report	
Declaration of Result (Result can also be viewed at website)	3 rd week of Sept.	3 rd week of March
*Certificates will be printed on the basis of student information on the Form		

Note : i) Above schedule is subject to change with prior Information to students. Also, can be viewed on

www.punjabinfotech.in

ii) Registration /Examination Dates in Joint PGDCA Course will be as per the guidelines of PSBTE (Details will be mailed to Cal-C Centre or can be viewed from website www.punjabinfotech.in)

iii) Exam Schedule is Subject to Change.

